

## Improving The Dynamic Performance of Two-area System Based Integration of RES

A. El-Bahnasawy<sup>1</sup>, Sherif M. Ali<sup>1</sup>, Tomonobu Senjyu<sup>2</sup>, Ayat A. Saleh<sup>1</sup>

<sup>1</sup> Department of Electrical Engineering, Faculty of Energy Engineering, Aswan University

<sup>2</sup> Department of Electrical and Electronics Engineering, Faculty of Engineering, University of the Ruckus, Nishihara, Japan

**Abstract**—In this paper, the impact of renewable energy sources on a Two-area system is discussed. Also green hydrogen system GHS and electrical vehicle charging system EVC are integrated to the system as loads. Simulation is carried out by MATLAB SOFTWARE and results are introduced to show the improvement of the dynamic performance of Two-area system based integration of renewable energy sources to the electric network. As deduced from the simulation results, the combination of a PV, wind, fuel cell renewable energy sources introduce better improvement of the tested system in terms of voltage profile.

**keywords** — *Two-area System, Renewable energy sources RES, PV System, Wind System, Fuel Cell System FC, Green Hydrogen system GHS, Electrical Vehicles Charging System EVC.*

### I. Introduction

The choice of using renewable energy resources RES instead of conventional sources is a suitable solution for environmental issues [1-5]. PV, and wind energy systems are the most worldwide used renewable energy sources with hydropower energy [6]. Also, fuel cell systems represent a clean source of energy [7].

In terms of loads, hydrogen production system could be utilized as a storage fuel with RES [8,9]. Electrical vehicles contribute to solve environmental problems over traditional vehicles [10]. EVC stations are taken into account as a distributed load over electrical networks [11].

Due to high penetration of RES in last decades, the impacts of RES on electrical power systems become an essential issue with the associated control techniques to mitigate RES integration problems [12-16].

To discuss the impact of RES integration on dynamic performance of electrical power systems, a Two-area power system is introduced and integrated with PV, wind, and FC systems as RES in addition to green hydrogen GH production system and EVC system as additional loads. MATLAB SOFTWARE is used for simulation with integration of different RES capacity scenarios.

The following sections discuss proposed studied model, RES models, additional loads models, and different scenarios of simulation and are followed by results and discussions.

### II. Studied System Model

The system under test is based on Kundur's Two-area System which is depicted in figure 1 and consists of two identical areas and are connected by a weak tie. Each area consists of two 900 MVA, 20 kV, and 60 Hz synchronous generators, two 900 MVA power transformer 20 /230 kV. Load 1 has power of 967 MW, and reactive power of 100

\*Corresponding author E-mail: [aelbahnasawy@energy.aswu.edu.eg](mailto:aelbahnasawy@energy.aswu.edu.eg)

Received February 14, 2024 received in revised form, April 18, 2024, accepted April 19, 2024.

(ASWJST 2021/ printed ISSN: 2735-3087 and on-line ISSN: 2735-3095)

<https://journals.aswu.edu.eg/stjournal>

Mvar. Load 2 has power of 1767 MW, and reactive power of 100 Mvar. Two shunt capacitors are connected at load buses each has reactive power of 200, and 350 Mvar respectively [17].

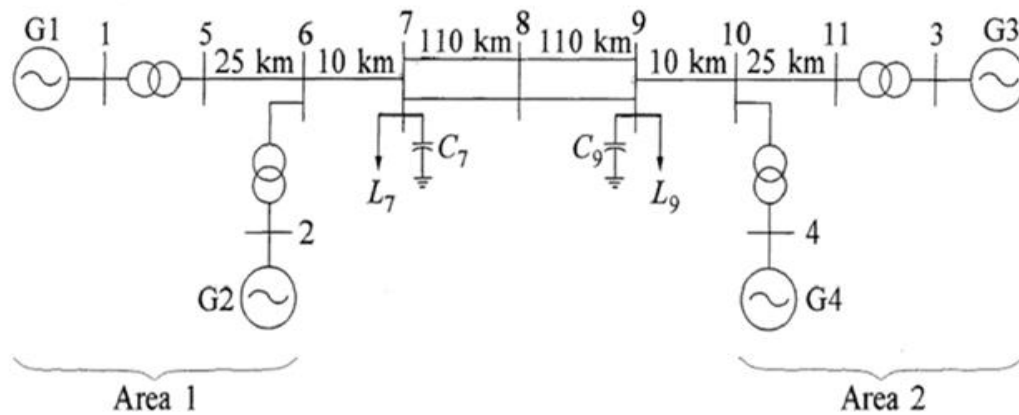

Figure 1. Topology of Kundur's Two-area system [17]

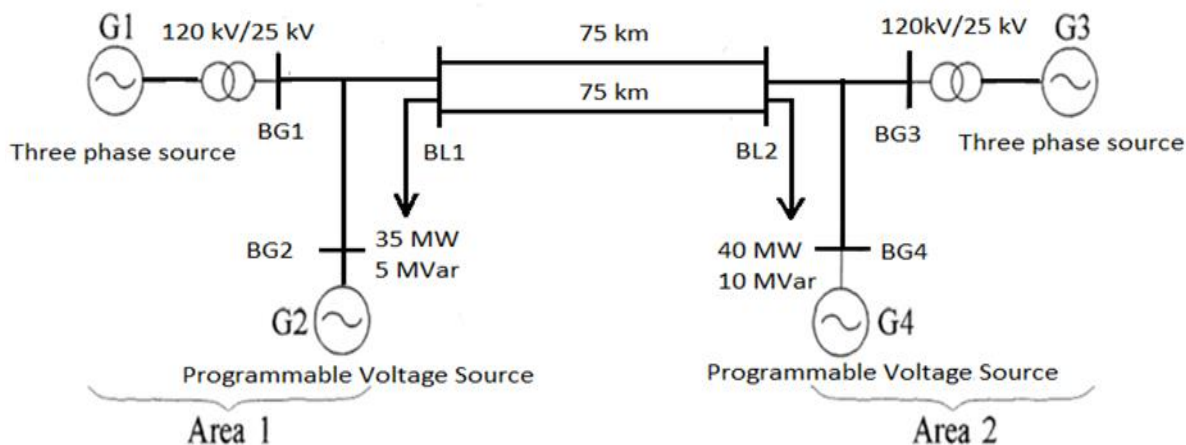

Figure 2. Topology of modified Two-Area test system

The concept of Kundur's Two-area System is used with less capacity to meet the RES systems capacities which are used in simulation. Modified test system topology and a SIMULINK schematic are shown in figure 2 and figure 3 respectively.

Modified Two-area test system is described as a 25 kv network consists of two areas. Each area consists of two generators. 120 kv three phase sources are connected to the network via a 120 / 25 kv power transformer [18], and two 25 kv programmable voltage sources [19]. The two areas are connected by two 75 km length transmission lines. A load of 35 MW and 5 MVar is connected to bus 1 BL1, and a load of 40 MW, 10 MVar is connected to bus 2 BL2.

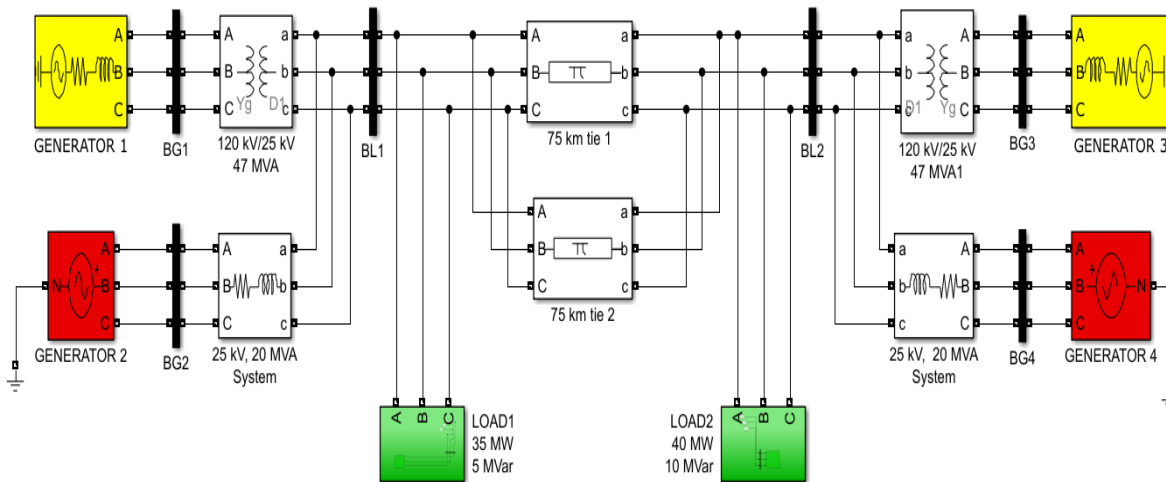

Figure 3. Modified Two-area test system schematic

### III. Renewable Energy Sources Models

**PV system model:** PV system model consists of a PV modules, boost converter is controlled by MPPT controller, Neutral point clamped inverter NPC converts 1000 V<sub>DC</sub> to 500 V<sub>AC</sub> and is controlled by a DC voltage regulator, and a transformer of 25 kV/500 V to connect to 25 kV system. Figure 4 shows a SIMULINK schematic of PV test system and figure 5 and figure 6 shows Simscape block parameters of one PV module and V-I curve of 9 MW PV system respectively [20]. The PV modules are connected in series to determine the required voltage forming strings. Strings are connected in parallel to determine the required capacity [21]. PV system capacity depends on different scenarios of simulation.

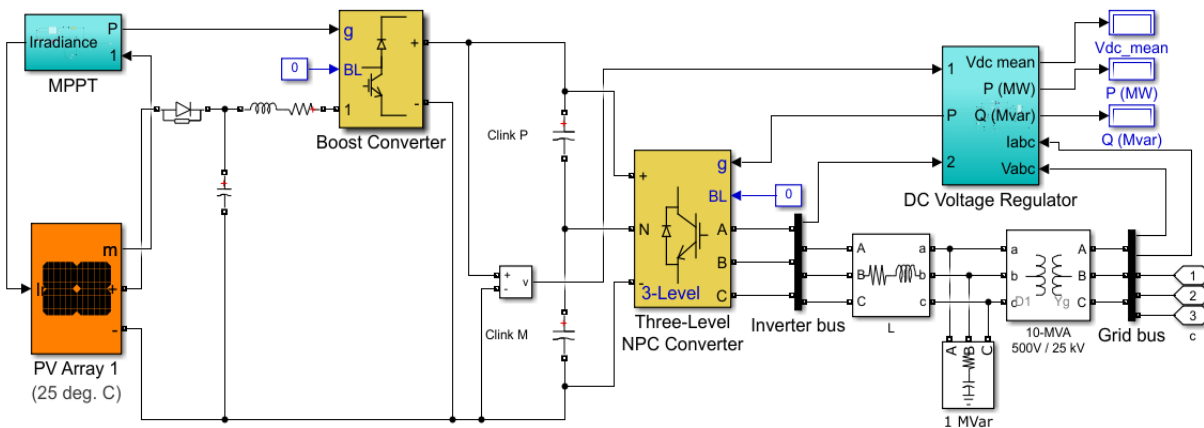

Figure 4. SIMULINK schematic of PV test system [20]

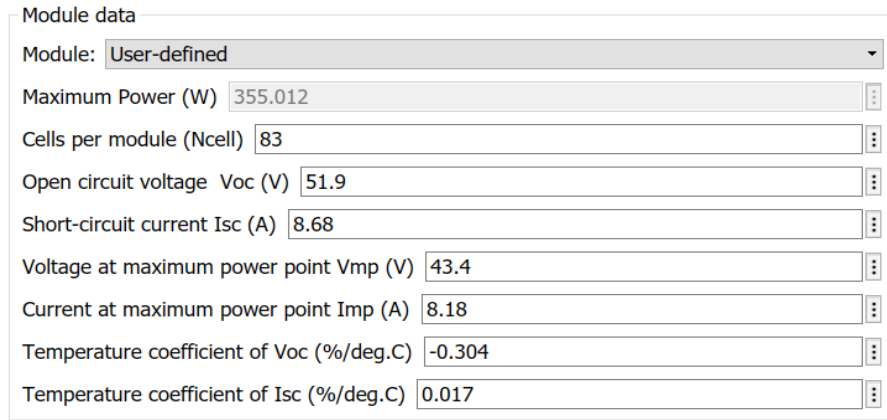

Figure 5. Simscape block parameters of one PV module [20]

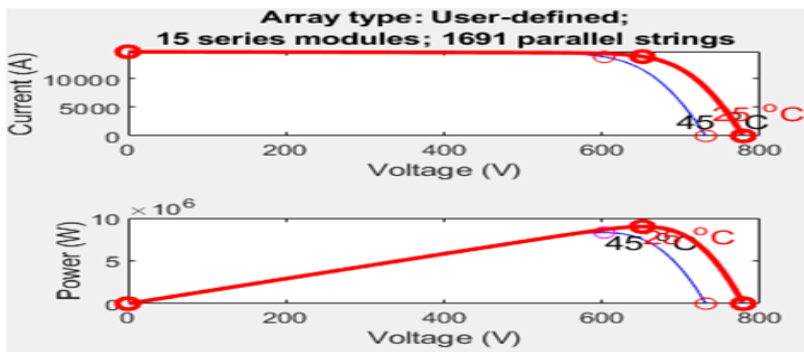

Figure 6. V-I curve of 9 MW PV test system [20]

**Wind system model:** Wind system model consists of a doubly fed induction generator DFIG, a torque controller, and a 25 kV / 575 V power transformer. DFIG consists of wound rotor generator its stator is connected directly to a 60 Hz grid, and its rotor is fed by IGBT-based PWM AC/DC/AC converter. Torque controller maintains speed at 1.2 pu of 15 m/s. Figure 7 shows a SIMULINK schematic of wind test system model and figure 8 shows wind test system Simscape block parameters [22].

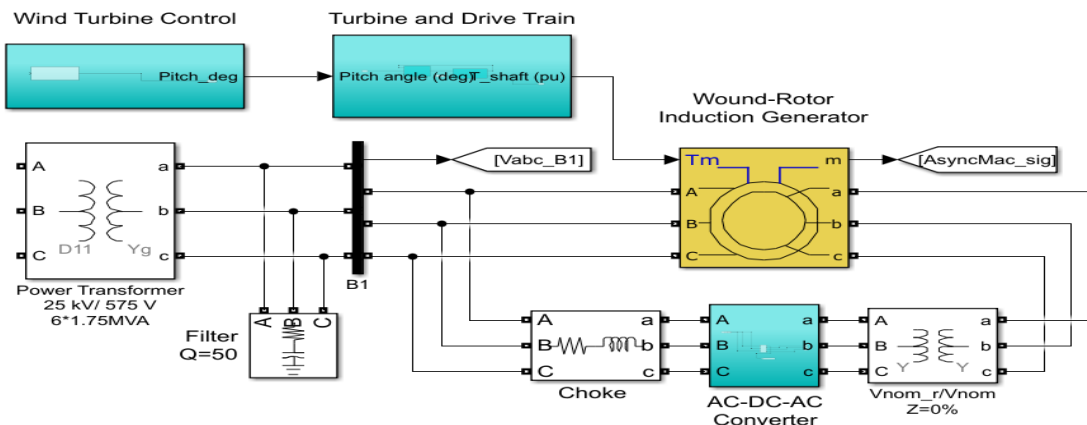
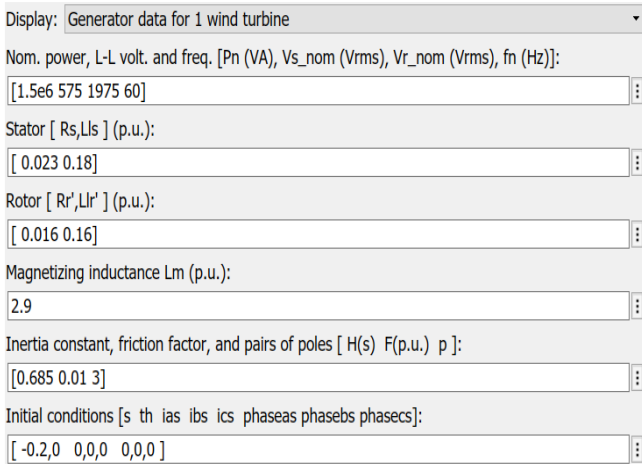
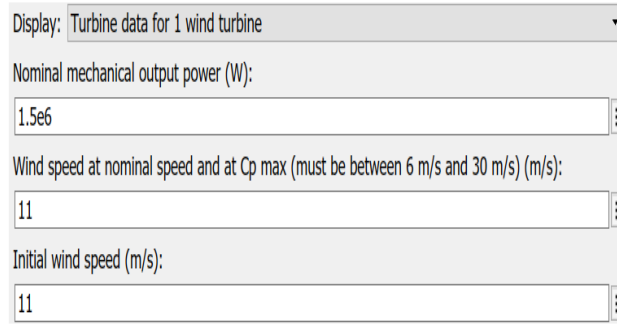

Figure 7. SIMULINK schematic of wind test system model [22]



(a)



(b)

Figure 8. Wind test system Simscape block parameters (a) Generator data (b) Turbine data [22]

**Fuel Cell System Model:** Proton Exchange Membrane fuel cell model is used. Figure 9 shows a SIMULINK schematic of fuel cell system. A fuel cell stack nominal operating voltage is 625 V<sub>DC</sub>, and has a power of 50 kW and refers to stack 45 fuel cell model of Matlab library [23]. The power grid matching, and control circuit of PV test system model is modified to control the output of fuel cell modules [20].

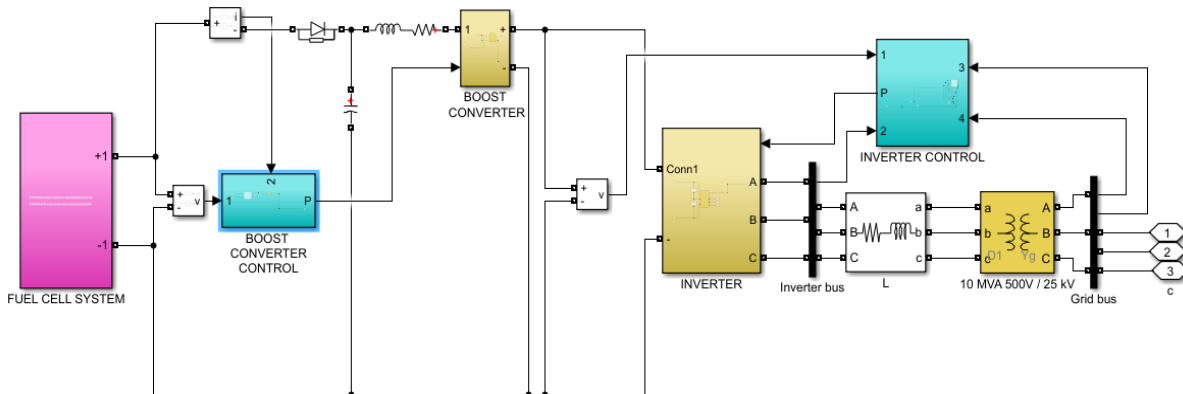

Figure 9. SIMULINK schematic of fuel cell system [20], [23]

**Green Hydrogen Production System Model:** An alkaline Electrolyzer SIMULINK model is constructed based on mathematical equations and real data. V-I characteristics and Hydrogen molar flow rate is given by equations 1 and 2 respectively. Figure 10 (a) shows a Simscape integration for the introduced GH Electrolyzer model [24].

$$V = V_{rev} + \frac{(r_1+r_2T)I}{A} + s \left( \log \left( \frac{I \left( t_1 + \frac{t_2}{T} + \frac{t_3}{T^2} \right)}{A+1} \right) \right) \dots \dots \dots (1)$$

where:

V= Applied voltage

T=Temperature

A=Area

$r_1, r_2$  Parameters related to ohmic resistance of electrolyte.

$s, t_1, t_2, t_3$  Coefficients for overvoltage on electrodes.

$V_{rev} = 1.229$

$$\dot{n}H_2 = \left( \frac{(I/A)^2}{f_1(I/A)^2} f_2 \right) \frac{I}{zF} \dots\dots\dots(2)$$

where:

$\dot{n}H_2$ = Hydrogen molar flow rate

$f_1, f_2$  Parameters related to the Faraday efficiency

F faraday constant = 96 485

$z = 2$

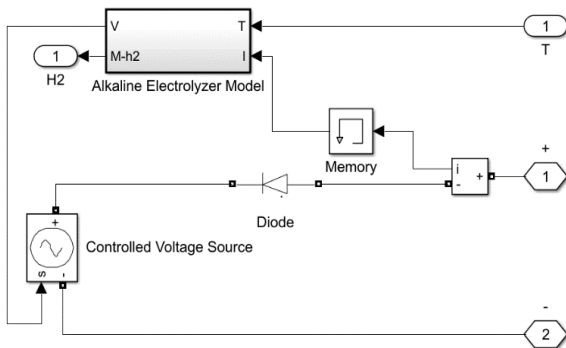

(a)

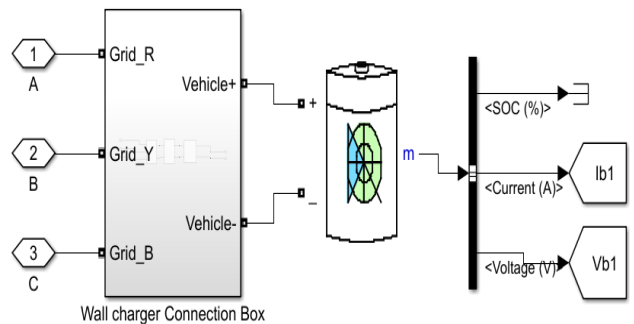

(b)

Figure 10. (a) a SIMULINK schematic of GH electrolyzer integration system [24] (b) a SIMULINK schematic of EVC model [25]

**EVs Charging System Model:** To add EVC system model, bidirectional charging system is modified to act in one direction (grid to vehicle) only. The model consists of a 25 kV / 380 V power transformer, AC/DC converter, buck boost converter, DC/DC converter with battery controller, and 230 V lithium ion battery. Figure 10 (b) shows a SIMULINK schematic of EV charger model [25].

### IV. Results and Discussions

The modified Two-area test system has six busbars, two load busbars BL1 and BL2 in addition to four generators busbars BG1, BG2, BG3, and BG4 as shown in figure 2. Total load of test system is 75 MW and 15 MVar is divided into two loads, load 1 is 35 MW and 5 MVar and load 2 is 40 MW and 10 MVar. EVC system and Electrolyzer loads are each of 16 MW.

Simulation process data and solver type are shown in table 1 and 100 MVA is taken as a base power. There are two scenarios to add RES to test system, 18 MW RES scenario and 27 MW RES scenario as shown in table 2. Four main scenarios of simulation are carried out by MATLAB SIMULINK Software to show the impact of integrating 18MW and 27 MW RES scenarios on a Two-area 75 MW / 15 MVar load power system as shown in table 3 and figure 11.

Different scenarios of RES, GH system, and EVC system are integrated to BL2 where minimum value of voltage for all simulation scenarios before integrating RES is shown in figure 12. Change of generator 3 active and reactive power are shown in figure 13 and figure 14 respectively for different simulation scenarios. Change of voltage and frequency at bus bar BL2 are shown in figure 15 and figure 16 respectively for different simulation scenarios.

Table 1. Data of MATLAB simulation process and solver type

Simulation type	Discrete
Simulation time	10 s
Sample time	2.5e-5 s
Solver type	Variable-step ode23tb
Relative tolerance	1e-3

Table 2. Scenarios of integrating 18 MW and 27 MW RES scenarios to Two-area system

RES scenario no.	18 MW RES scenario			27 MW RES scenario		
	PV system (MW)	WIND system (MW)	FC system (MW)	PV system (MW)	WIND system (MW)	FC system (MW)
1	18	-	-	27	-	-
2	-	18	-	-	27	-
3	-	-	18	18	9	-
4	9	9	-	9	18	-
5	9	-	9	18	-	9
6	-	9	9	-	18	9
7	6	6	6	9	9	9

Table 3. Simulation scenarios`

Simulation Scenario no.	Studied Test system	RES scenarios integration (table 2)	No. of simulation sub-scenarios
1	Modified Two-area system	18 MW	8
2	Modified Two-area system+16 MW EVC	18 MW	8
3	Modified Two-area system+16 MW GHS	18 MW	8
4	Modified Two-area system+16 MW EVC+16 MW GHS	27 MW	8

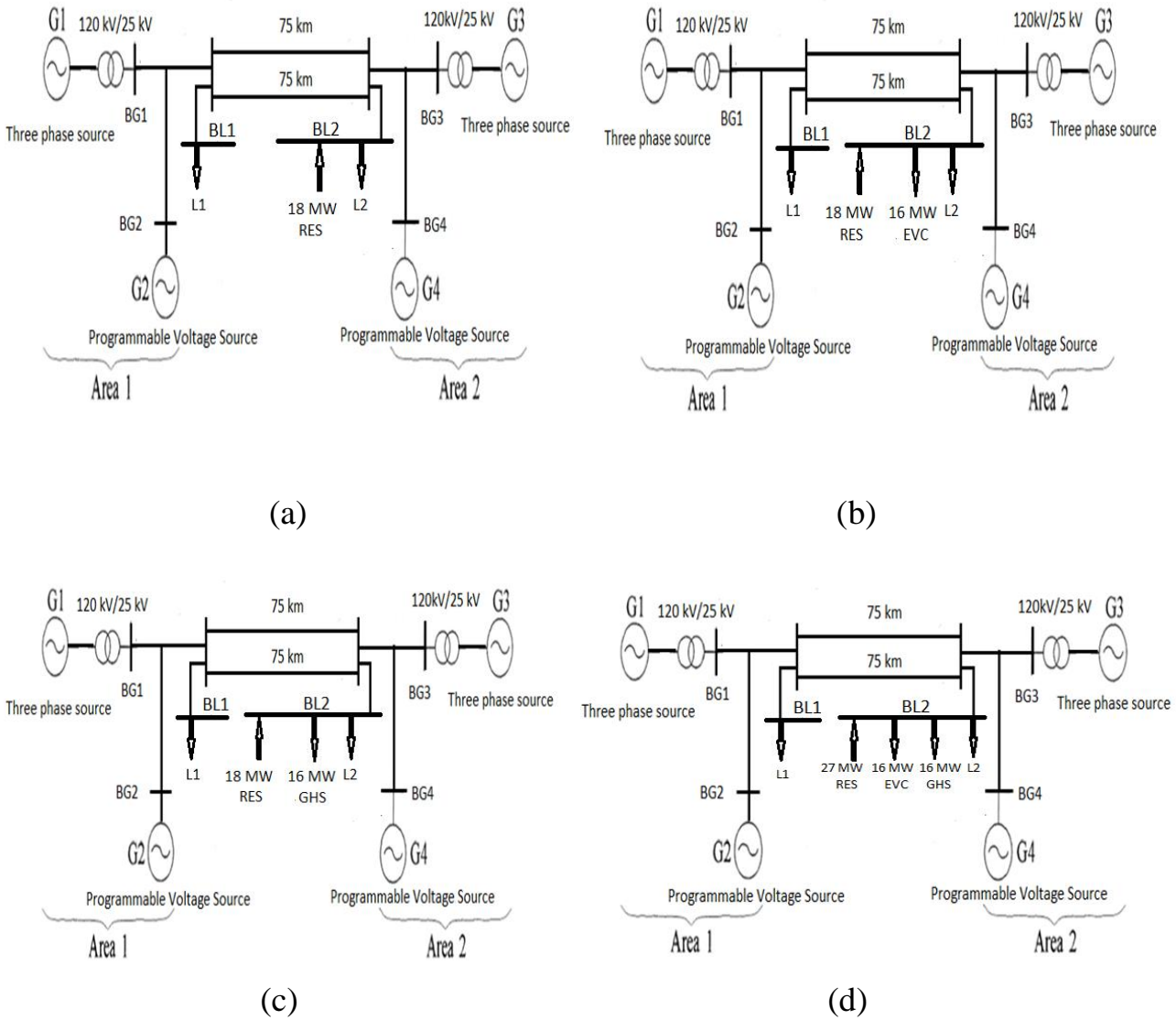
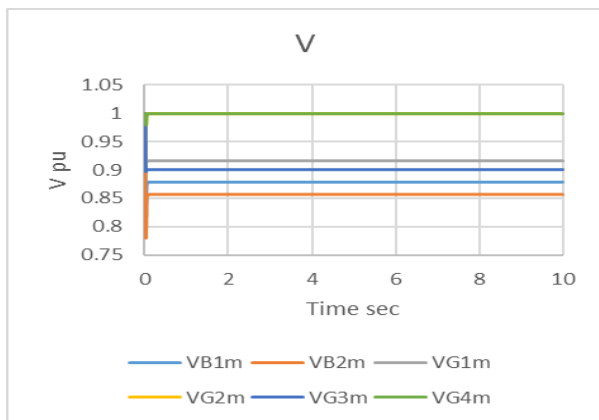
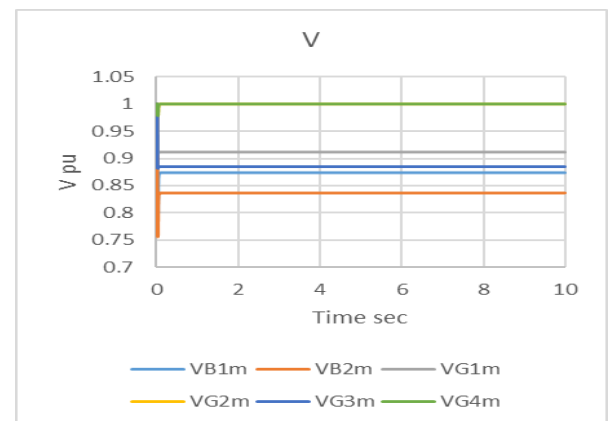

Figure 11. Modified Two-area test system topology with different simulation scenarios (a) scenario 1 (b) scenario 2 (c) scenario 3 (d) scenario 4



(a)



(b)



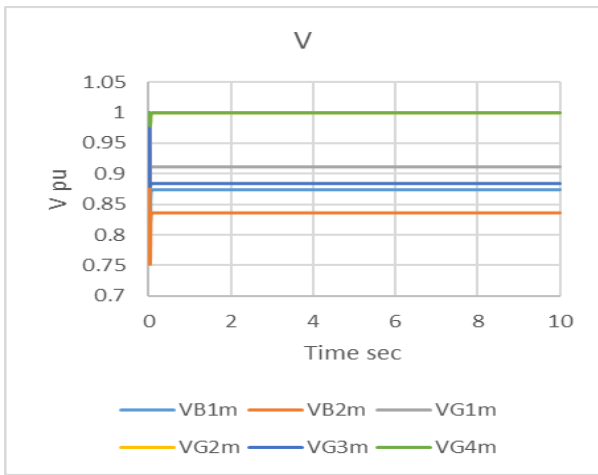

(c)

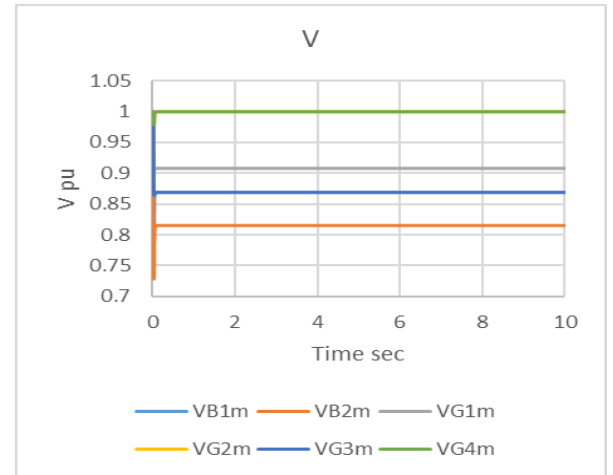

(d)

Figure 12. Simulation results of the test system voltages before integrating RES (a) scenario 1 (b) scenario 2 (c) scenario 3 (d) scenario 4

After simulation of the Two-area test system before integrating RES, voltage at busbar BL2 has mi value of voltage as shown in figure 12 and table 4.

Table 4. Voltage values at bus BL2 before integrating RES for different simulation scenarios at the end of simulation time

Simulation Scenario no.	Bus BL2 Voltage (pu)
1	0.856597
2	0.836361
3	0.836139
4	0.815485

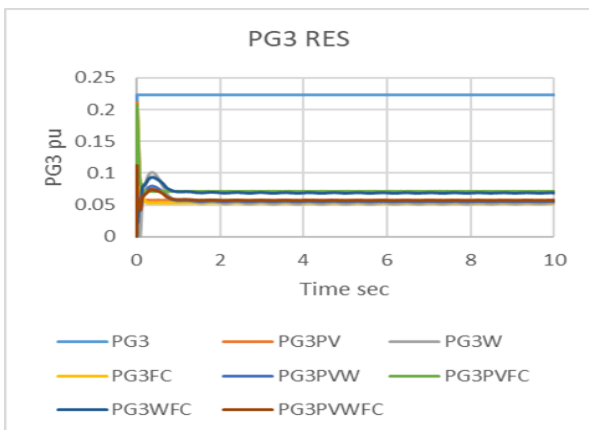

(a)

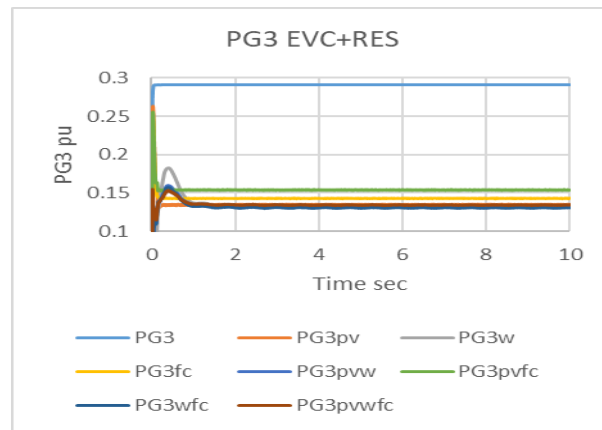

(b)

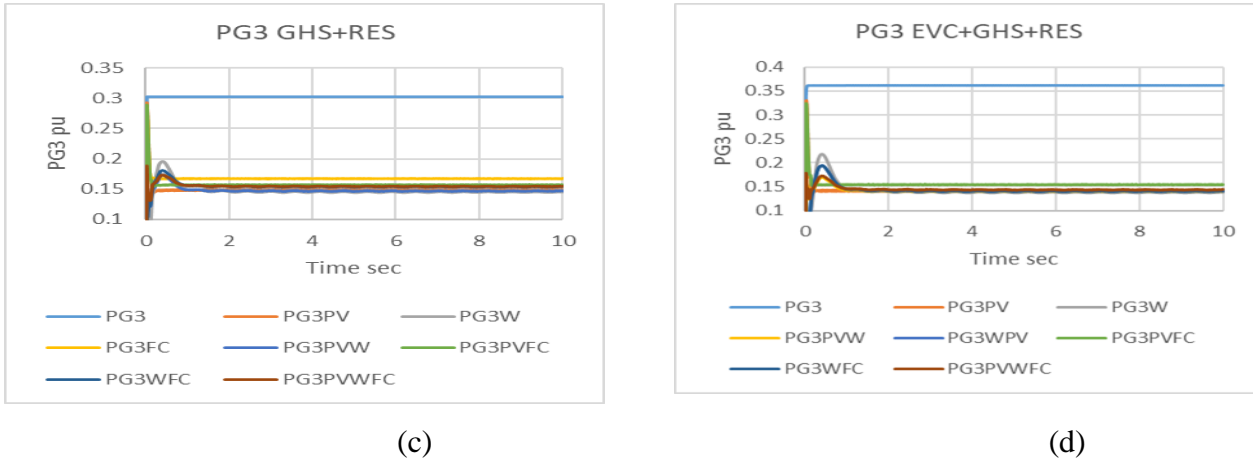
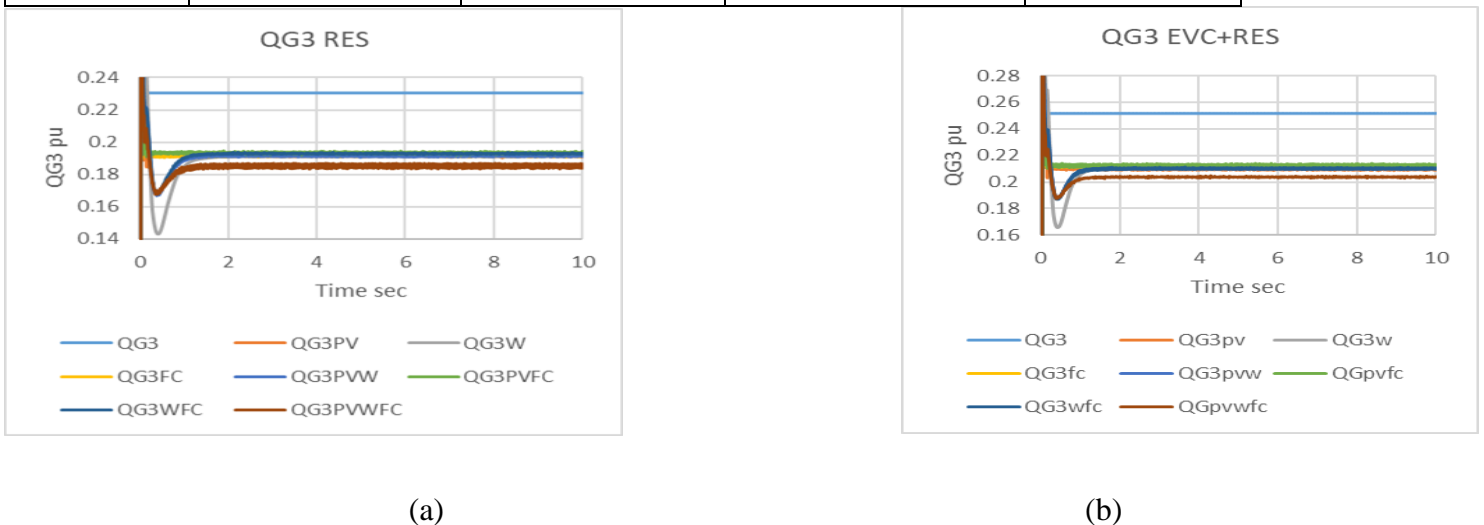

Figure 13. Simulation results, active power of generator 3 (a) scenario 1 (b) scenario 2 (c) scenario 3 (d) scenario 4

Power of generators decreases after integrating RES and generator 3 has the most change of power after integrating RES specially with wind system (scenario 1, 3, and 4) and W-FC system (scenario 2) as shown in figure 13 and table 5.

Table 5. Power values of generator 3 before and after integrating RES for different simulation scenarios at the end of simulation time

Simulation Scenario no.	Power of Generator 3 (pu)			
	Before integrating RES	After integrating RES		Change value
		Min. value	RES sub-scenario	
1	0.223583	0.052655	Wind system	- 0.170928
2	0.291457	0.130874	W-FC system	- 0.160583
3	0.302236	0.145213	Wind system	- 0.157023
4	0.362106	0.138163	Wind system	- 0.223943



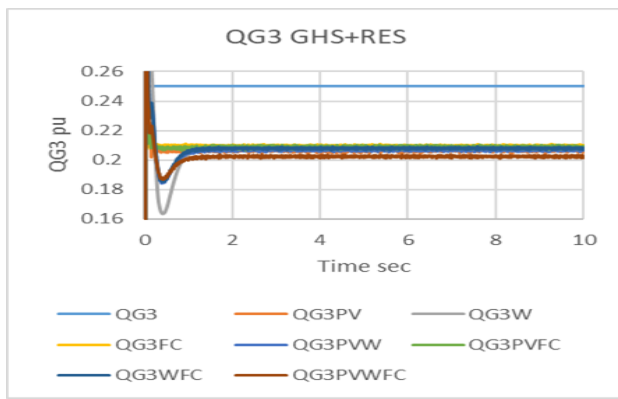

(c)

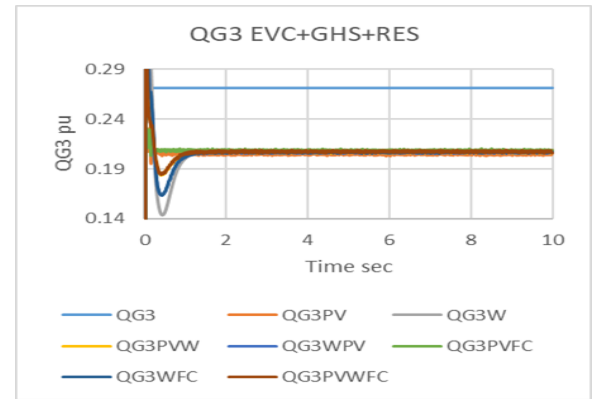

(d)

Figure 14. Simulation results, reactive power of generator 3 (a) scenario 1 (b) scenario 2 (c) scenario 3 (d) scenario 4

Reactive power of generators decreases after integrating RES and generator 3 has the most change of reactive power after integrating RES specially with PV-W-FC system as shown in figure 14 and table 6.

Table 6. Reactive power values of generator 3 before and after integrating RES for different simulation scenarios at the end of simulation time

Simulation Scenario no.	Reactive Power of Generator 3 (pu)			
	Before integrating RES	After integrating RES		Change value
		Min. value	RES sub-scenario	
1	0.230232	0.185699	PV-W-FC	- 0.044533
2	0.251766	0.203730	PV-W-FC	- 0.048036
3	0.250420	0.202183	PV-W-FC	- 0.048237
4	0.271698	0.206044	PV-W-FC	- 0.065654

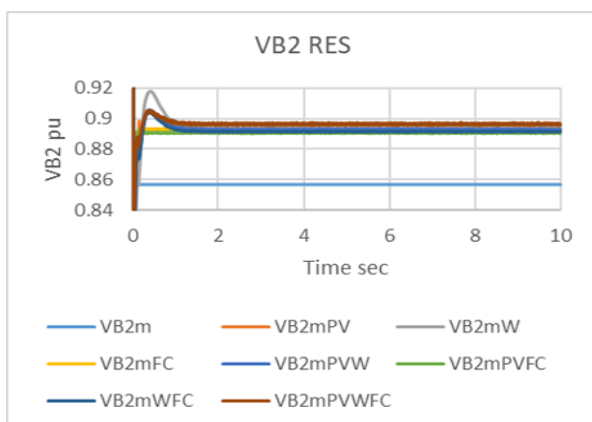

(a)

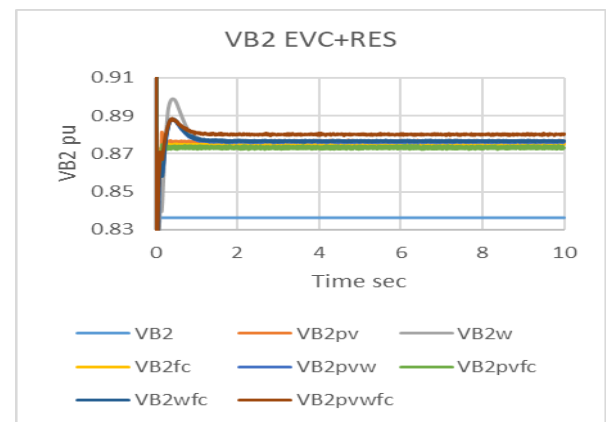

(b)

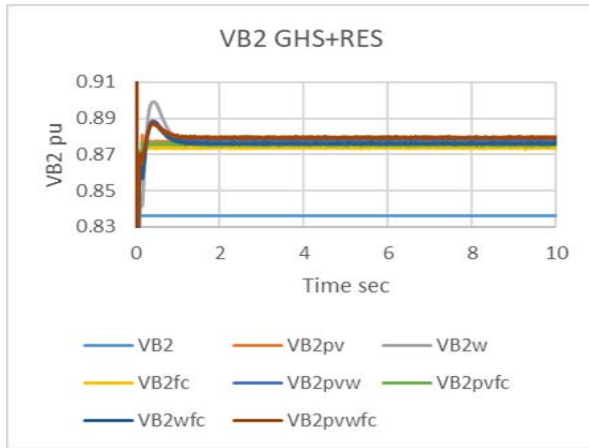

(c)

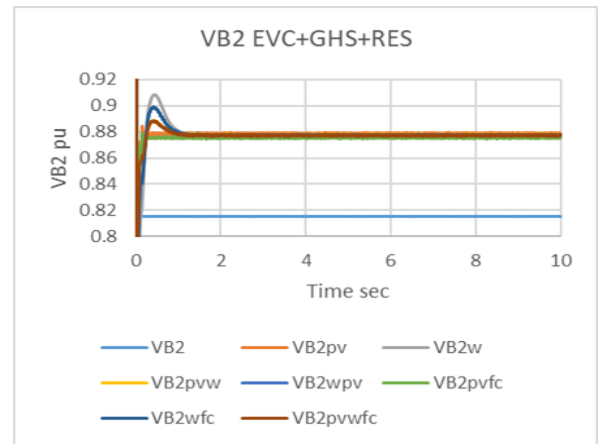

(d)

Figure 15. Simulation results, voltage at bus BL2 (a) scenario 1 (b) scenario 2 (c) scenario 3 (d) scenario 4

Voltage of all busses are improved after integrating RES specially with PV-W-FC system. BL2 voltage change is shown in figure 15 and table 7.

Table 7. Voltage values at BL2 before and after integrating RES for different simulation scenarios at the end of simulation time

Simulation Scenario no.	Voltage at bus bar BL2 (pu)			
	Before integrating RES	After integrating RES		Change value
		Max. value	RES sub-scenario	
1	0.856597	0.896400	PV-W-FC	+ 0.039803
2	0.836361	0.880541	PV-W-FC	+ 0.044180
3	0.836139	0.879419	PV-W-FC	+ 0.043280
4	0.815485	0.878250	PV-W-FC	+ 0.062765

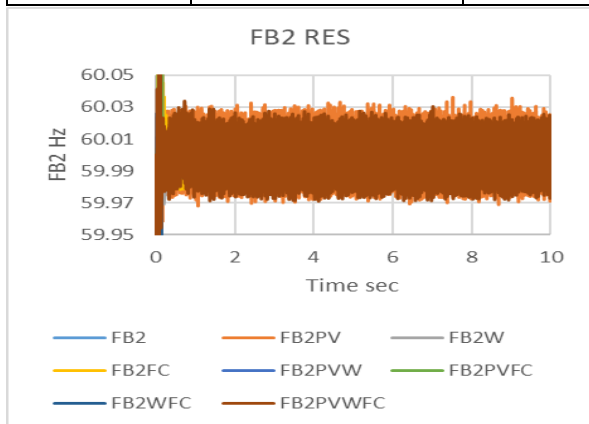

(a)

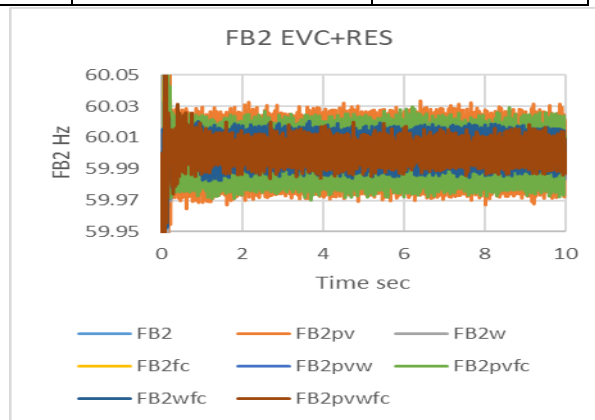

(b)

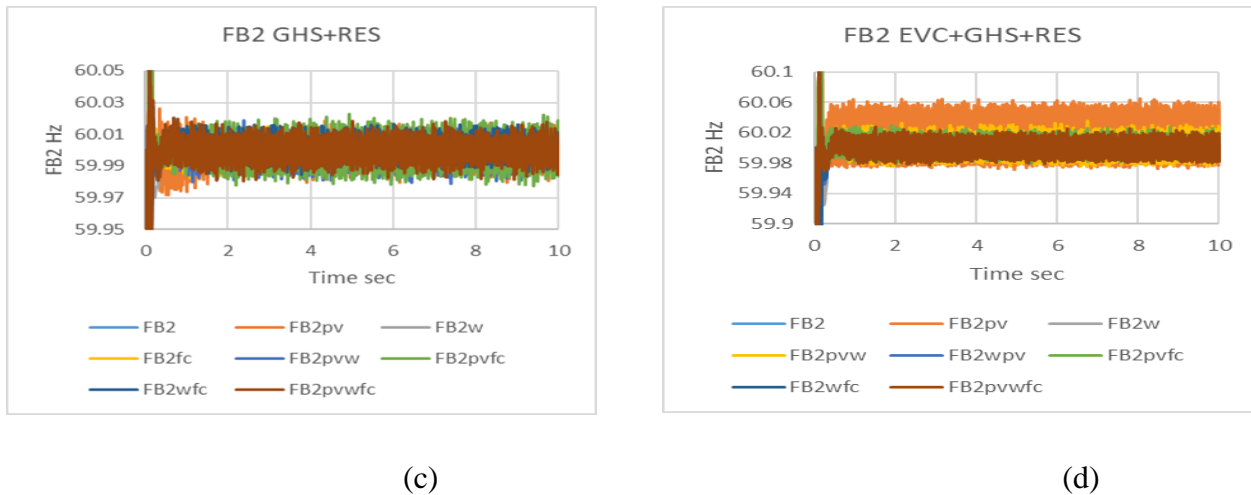

Figure 16. Simulation results, frequency at bus BL2 (a) scenario 1 (b) scenario 2 (c) scenario 3 (d) scenario 4

Oscillation occurs in frequency in case of integrating PV, FC, and PV-FC combinations due to simulation at discrete mode as shown in figure 16.

## V. Conclusions

RES integration to the Two-area studied system contributes improving the system in terms of voltage profile. Oscillation occurs in frequency in case of integrating PV, FC, and PV-FC combinations due to simulation at discrete mode and introducing proper control circuits and better filters design may help to mitigate such oscillation. Best active power behavior is achieved with wind system (scenario 1, 3, and 4) and W-FC system (scenario 2). Best reactive power behavior and voltage improvement is achieved with PV-W-FC system (in all scenarios).

For future works, it is recommended to study

1. Impact of RES on power systems quality.
2. Impact of integrating RES on protection systems.
3. Optimizing the parameters of RES for improving the system dynamic performance.
4. Investigate the impact of RES on transient stability of power systems.

## REFERENCES

- [1] He X et al. "The role of renewable energy investment in tackling climate change concerns: Environmental policies for achieving SDG-13." *Sustainable Development*. (1)(2023).
- [2] Owusu, Phebe Asantewaa, and Samuel Asumadu-Sarkodie. "A review of renewable energy sources, sustainability issues and climate change mitigation." *Cogent Engineering* 3.1 (2016): 1167990.
- [3] Olabi A. G., and Mohammad Ali Abdelkareem. "Renewable energy and climate change." *Renewable and Sustainable Energy Reviews* 158 (2022): 112111.
- [4] Candra Oriza et al. "The impact of renewable energy sources on the sustainable development of the economy and greenhouse gas emissions." *Sustainability* 15, no. 3 (2023): 2104.
- [5] Osman Ahmed I. et al. "Cost, environmental impact, and resilience of renewable energy under a changing climate: a review." *Environmental Chemistry Letters* 21, no. 2 (2023): 741-764.
- [6] <https://www.iea.org/energy-system/renewables/solar-pv> (2023).

- [7] Felseghi Raluca-Andreea et al. "Hydrogen fuel cell technology for the sustainable future of stationary applications." *Energies* 12.23 (2019): 4593.
- [8] Ishaq Haris, Ibrahim Dincer, and Curran Crawford. "A review on hydrogen production and utilization: Challenges and opportunities." *International Journal of Hydrogen Energy* 47.62 (2022): 26238-26264.
- [9] Kakoulaki Georgia et al. "Green hydrogen in Europe—A regional assessment: Substituting existing production with electrolysis powered by renewables." *Energy Conversion and Management* 228 (2021): 113649.
- [10] Sun Xiaoli et al. "Technology development of electric vehicles: A review." *Energies* 13, no. 1 (2019): 90.
- [11] Sanguesa Julio A. et al. "A review on electric vehicles: Technologies and challenges." *Smart Cities* 4.1 (2021): 372-404.
- [12] Impram Semich, Secil Varbak Nese, and Bülent Oral. "Challenges of renewable energy penetration on power system flexibility: A survey." *Energy Strategy Reviews* 31 (2020): 100539.
- [13] Alam Md Shafiul et al. "High-level penetration of renewable energy sources into grid utility: Challenges and solutions." *IEEE Access* 8 (2020): 190277-190299.
- [14] Bødal Espen Flo et al. "Challenges in distribution grid with high penetration of renewables." (2018).
- [15] Medina Carlos C., Ríos M. Ana, and Guadalupe González. "Transmission grids to foster high penetration of large-scale variable renewable energy sources—A review of challenges, problems, and solutions." *International Journal of Renewable Energy Research (IJRER)* 12.1 (2022): 146-169.
- [16] Ranjan Mrinal, and Ravi Shankar. "A literature survey on load frequency control considering renewable energy integration in power system: Recent trends and future prospects." *Journal of Energy Storage* 45 (2022): 103717.
- [17] Prabha Kundur. "Power System Stability and Control." The EPRI Power System Engineering Series, 1994, McGraw-Hill, ISBN 0-07-035958-X.
- [18] Matlab version 9.10.0 (2021a), Initializing a 5-Bus Network with the Load Flow Tool of Powergui Open Model, G. Sybille (Hydro-Quebec), The MathWorks Inc.; (2021).
- [19] Matlab version 9.10.0 (2021a), D-ATATCOM (Average model), Pierre Giroux ; Gilbert Sybille (Hydro-Quebec, IREQ), The MathWorks Inc.; (2021).
- [20] Matlab version 9.10.0 (2021a), 2-MW PV Farm Connected to a 25-kV Distribution System, The MathWorks Inc.; (2021).
- [21] Shimizu Toshihisa et al. " Generation control circuit for photovoltaic modules." *Power Electronics, IEEE Transactions on power electronics.* 16.3(6)(2001):293 - 300.
- [22] Matlab version 9.10.0 (2021a), Wind farm – DFIG average model, Richard Gagnon (Hydro-Quebec), The MathWorks Inc.; (2021).
- [23] Matlab version 9.10.0 (2021a), SIMULINK library, The MathWorks Inc.; (2021).
- [24] D. Martinez, and R. Zamora, "MATLAB Simscape Model of An Alkaline Electrolyser and Its Simulation with A Directly Coupled PV Module for Auckland Solar Irradiance Profile", *International Journal of Renewable Energy Research*, 8(2018): 552-560.
- [25] Matlab version 9.10.0 (2021a), Electric Vehicle bi directional V2G & G2V, The MathWorks Inc.; (2021).